

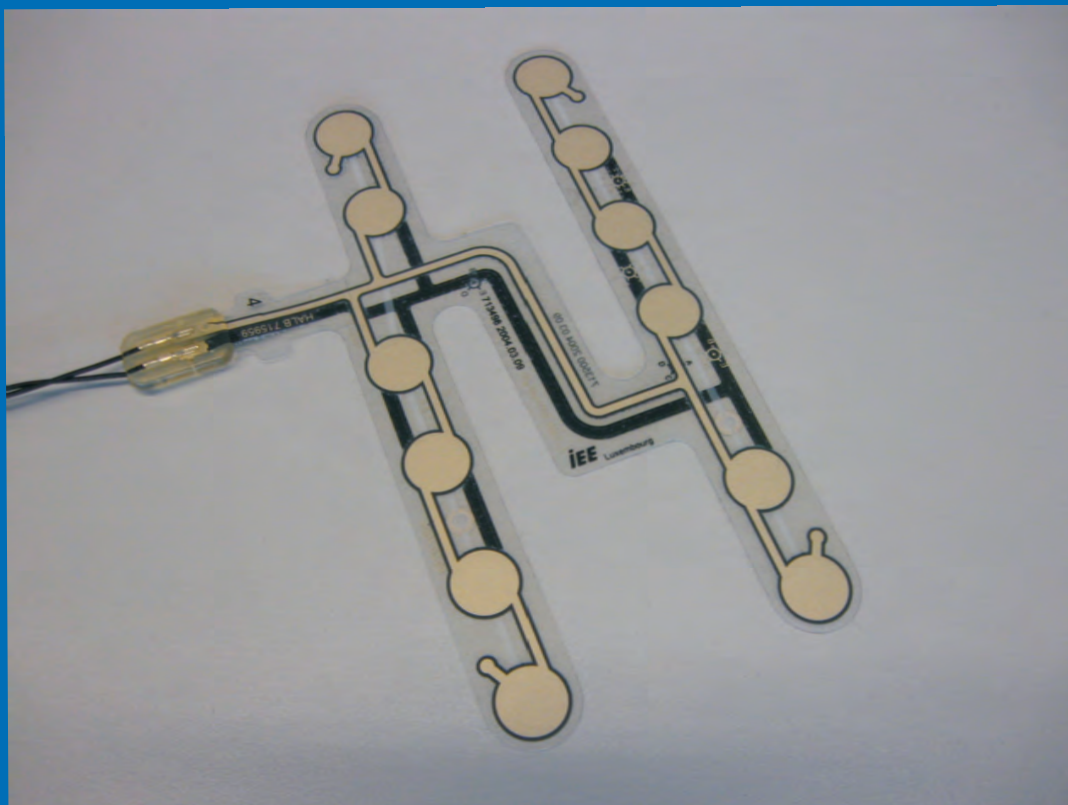

SIT-SBR-5



The features

- recognizes persons over 15 kg
- no calibration necessary during lifetime
- simple and secure system

SIT-SBR Passenger detection

SIT-SBR-5

Seat sensors

Advantages

- Reliable passenger detection ensured in combination with HALE taximeter
- No failures because of seat adjustments or repositionings.
- The SBR mats can be installed in the passenger and rear bench seats and are electronically linked to the taximeter.
- The SBR thick film sensors adapt to most seat designs including front and rear benches.
- The system needs no initial calibration, nor re-calibration during its lifetime.
- The SBR is easily placed and fixed under the seat cover.
- The round sensor areas allow comprehensive occupant detection.
- Also useable in combination with the HALE light barrier sensor LSS-4.

Available versions

- SIT-SBR-5 with fleece mat
- SIT-SBR-5-100 with fleece mat, 100 pcs.

Technical data SIT-SBR

Voltage range	U = 3,5 - 18 V
Current range	I = 0 - 14 mA
Cable length	3 meters
Potential-free contact	



HALE - the future in TAXI

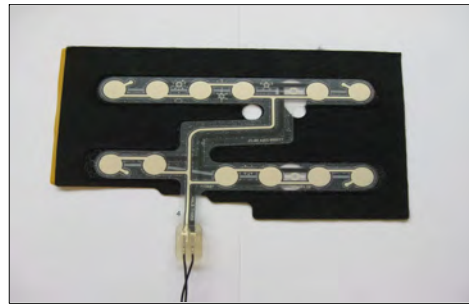

SIT-SBR-5

Seat sensor solutions

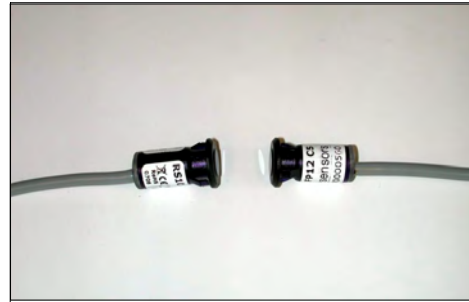

LSS-4

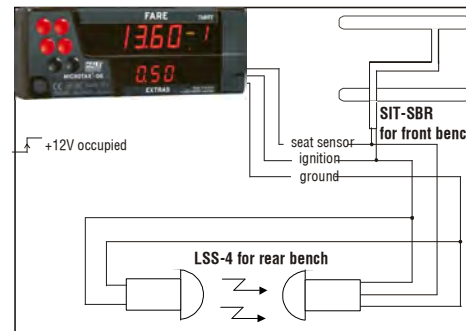

Combination SIT-SBR 5 and LSS-4

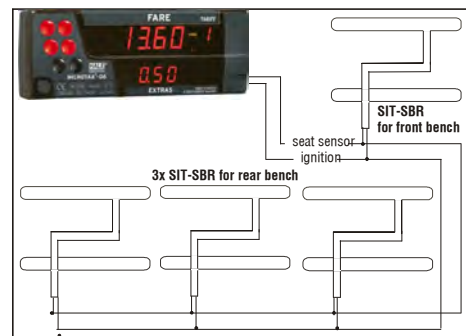

SIT-SBR-5-SET
4x SIT-SBR-5 incl. cable tree (3/2/0,5/0,5m)

HALE electronic GmbH
Eugen-Müller-Str. 18
A-5020 Salzburg
Tel.: +43 (662) 439011-0
Fax: +43 (662) 439011-9
marketing@hale.at
www.hale-electronic.com